

USER GUIDE

San Nicolas 30" Stainless Steel Vanity Set w/Mirror



Model #: 98300185

(Faucets and other display items not included)

PACKAGING CONTENTS



(P1: 98300185-C)

- Metal cabinet x1
- Plastic anchor x4
- Screw x4

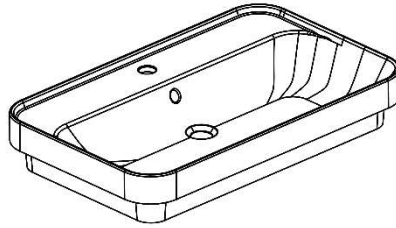

(P2: 98300185-B)

- Basin x1

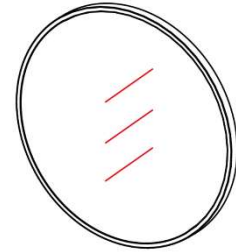

(P3: 98300185-M)

- Mirror x1
- Plastic anchor x2
- Screw x2

INSTALLATION DIMENSIONS

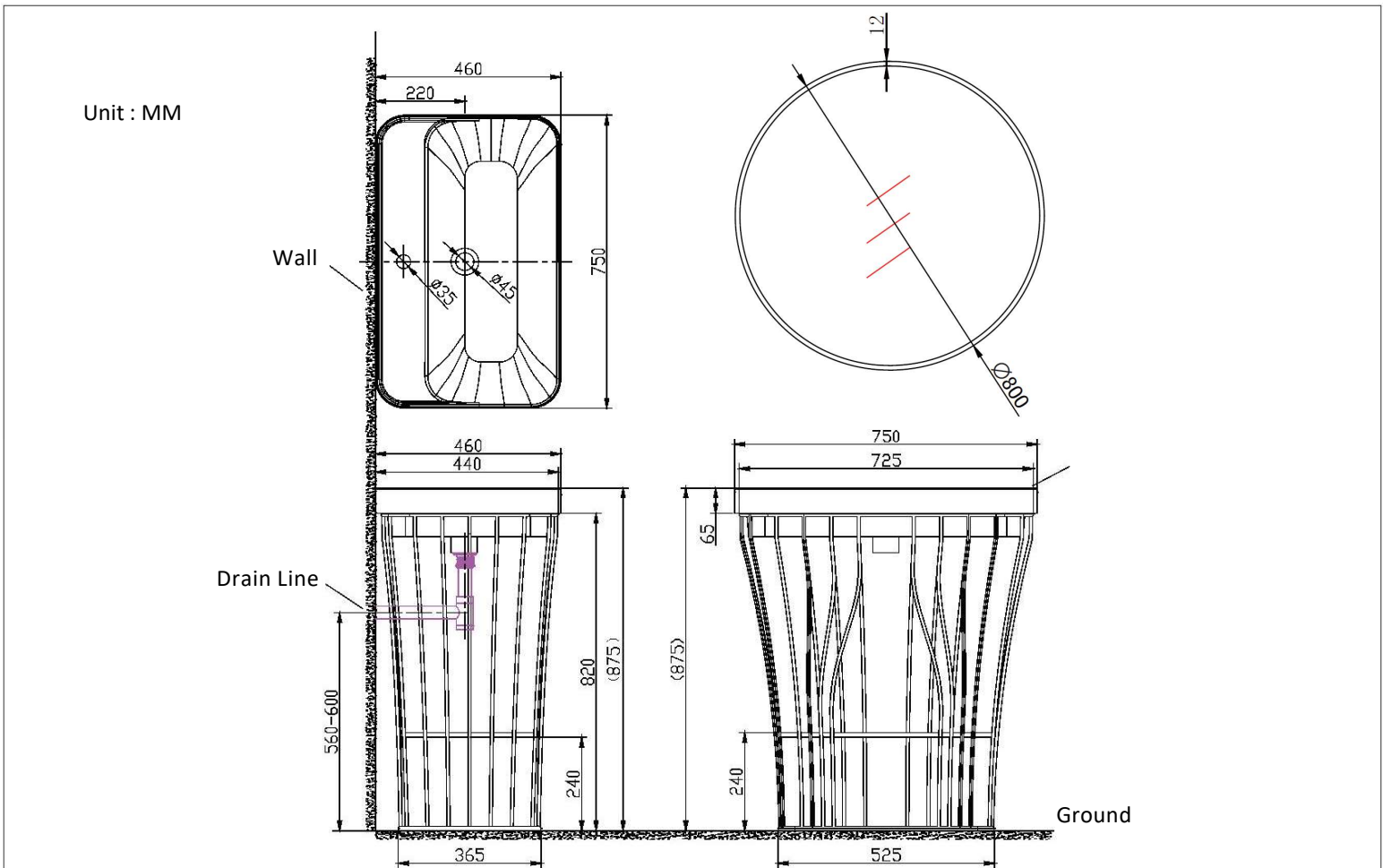

INSTALLATION

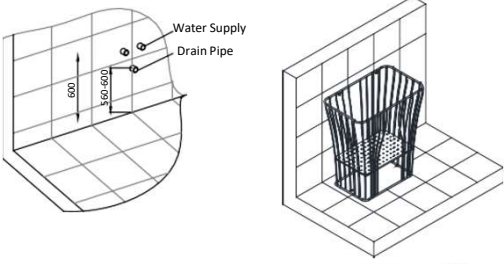
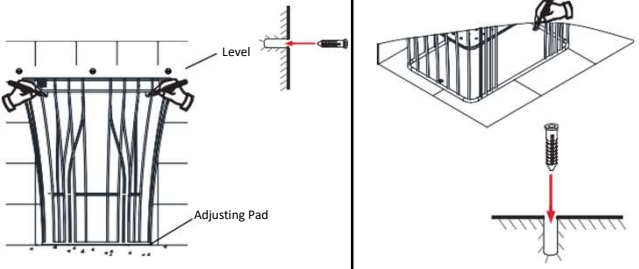
<p>1</p> 	<p>Install the cabinet</p> <ol style="list-style-type: none">1. Place the bathroom cabinet in a suitable location against the wall.2. Adjust the levelers to level the cabinet and mark the mounting hole location.3. Drill holes and insert anchors
	

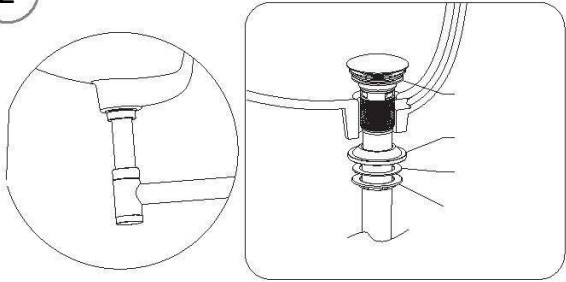
<p>2</p> 	<p>Install the pop-up drain (not included) to basin</p>
---	--

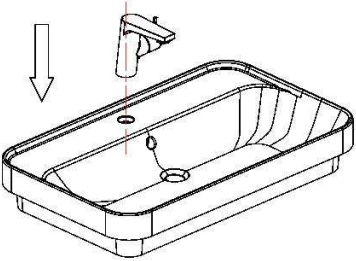
<p>3</p> 	<p>Install faucet (not included) to the basin according to the faucet manufacturer's instructions.</p>
--	---

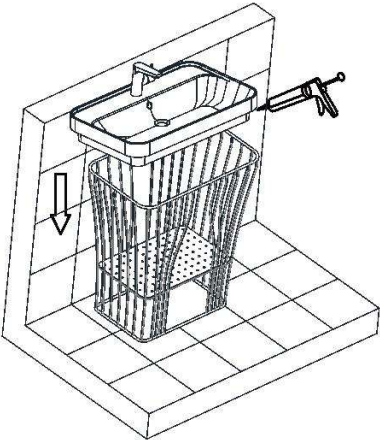
<p>4</p> 	<p>Attach basin to cabinet</p> <ol style="list-style-type: none">1. Apply small amount of silicone around the outer edge of the basin and fit it into the cabinet.
--	---

INSTALLATION (Continue)

5

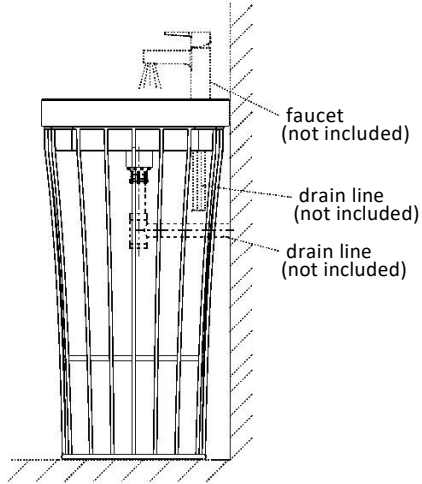

Connect the plumbing fixtures

1. Connect the pop-up drain with the drain line
2. Connect the faucet water supply lines

6

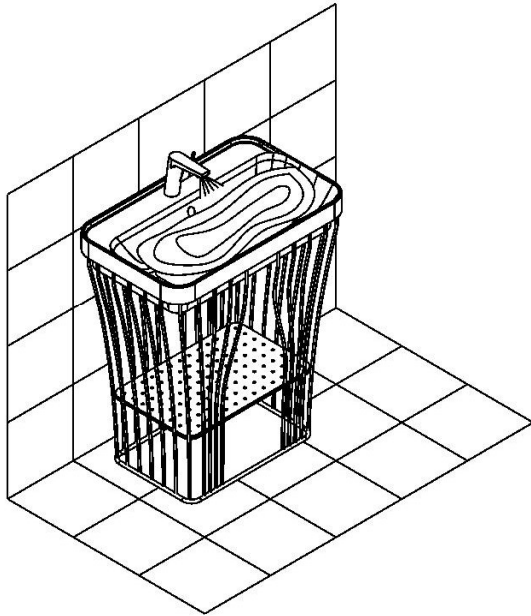

Leak check

1. Check ALL plumbing connections and make sure there is no leak.

7

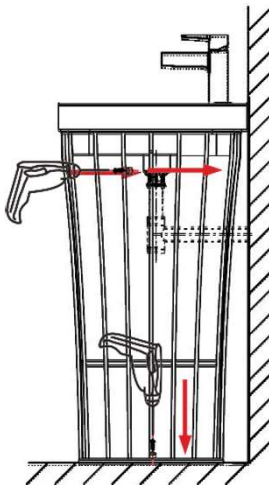

Fixing the cabinet to the wall

1. Put the screws through the mounting holes on the cabinet and into the anchors install in Step 1.

INSTALLATION (Continue)

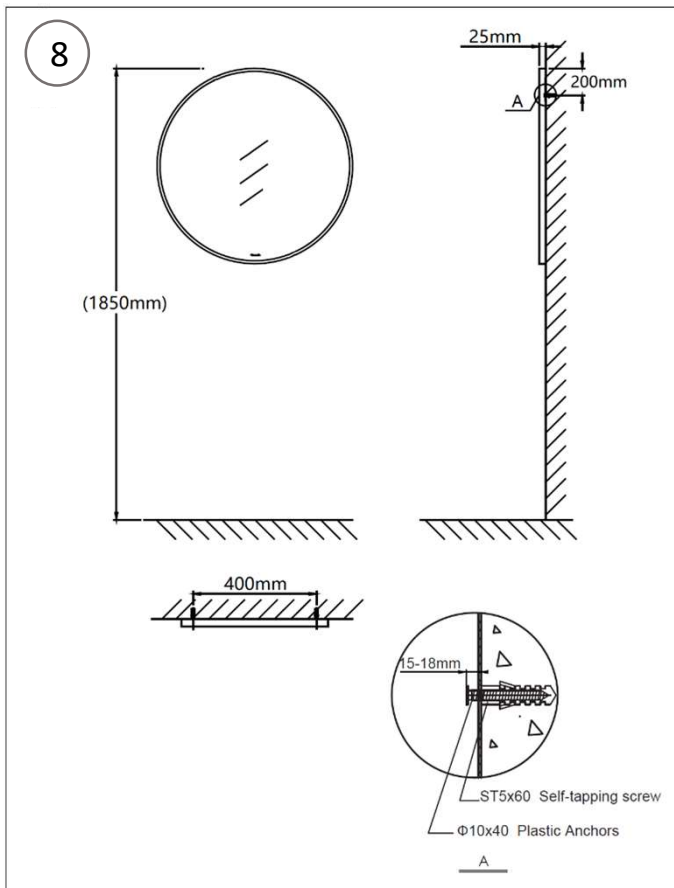

Mirror Installation

1. Drill holes to install plastic anchors per drawing.
2. Insert screws into the anchors per drawing.
3. Hang the mirror onto the screws.

CARE AND MAINTENANCE

Metal Cabinet and Mirror Frame

Keep the bathroom well ventilated and avoid direct sunlight. Check the plumbing connections regularly to avoid leakage and water damages.

A soft cotton cloth dampened with warm water is usually sufficient for cleaning your metal cabinets. If more thorough cleaning is required, please use a fresh solution of mild hand dishwashing liquid mixed with warm water. After cleaning, wipe all surfaces with a clean, damp cloth. Dry immediately using another soft, clean cloth.

Avoid using harsh or abrasive cleaning products, such as, tub and sink cleansers, scouring pads, scouring powder, steel wool or self polishing waxes. Avoid using solvent-based or petroleum-based products, such as, mineral spirits nail-polish removers or paint thinners.

WARRANTY

Innoci usa provides a 30-Day Return Window (see Return of Non-Defective Products below) and the following limited warranty. This limited warranty extends only to the original purchaser. Please note that the order number must accompany any warranty services or questions from the transaction through which the warranted product was purchased. **The order number serves as your warranty number and must be retained.** **Innoci usa** will offer no warranty service without this number.

Innoci usa warrants this product and its parts against defects in materials or workmanship for **One Year** from the original ship date. During this period, **Innoci usa** will repair or replace defective parts with new or reconditioned parts without charge to you. Shipping fees incurred from returns for under-warranty service in the first 30-days will be paid by **Innoci usa**. All shipping fees both to and from **Innoci usa** following this 30-day period must be paid by the customer. All returns, both during and following the 30-day period, must be affected via the Procedures for Obtaining Warranty Service described below.

All original parts (parts installed by **Innoci usa**, replaced by **Innoci usa** or its authorized service center, become the property of **Innoci usa**. Any after-market additions or modifications will not be warranted.

Innoci usa makes no other warranty, either express or implied, including but not limited to implied warranties of merchantability, fitness for a particular purpose, or conformity to any representation or description, with respect to this Vanity other than as set forth below. **Innoci usa** makes no warranty or representation, either express or implied, with respect to any other manufacturer's product or documentation, its quality, performance, merchantability, fitness for a particular purpose, or conformity to any representation or description.

Except as provided below, **Innoci usa** is not liable for any loss, cost, expense, inconvenience or damage that may result from use or inability to use the Vanity. Under no circumstances shall **Innoci usa** be liable for any loss, cost, expense, inconvenience or damage exceeding the purchase price of the Vanity.

The warranty and remedies set forth below are exclusive and in lieu of all others, oral or written, expressed or implied. No reseller, agent or employee is authorized to make any modification, extension or addition to this warranty.

Warranty Conditions

The above Limited Warranty is subject to the following conditions:

This warranty extends only to products distributed and/or sold by **Innoci usa**. It is effective only if the products are purchased and operated in the USA. (Within the USA including US 48 States, Alaska and Hawaii and Canada.)

This warranty covers only normal use of the Vanity. **Innoci usa** shall not be liable under this warranty if any damage or defect results from (i) misuse, abuse, neglect, improper shipping or installation; (ii) disasters such as fire or flood. You must retain your bill of sale or other proof of purchase to receive warranty service.

WARRANTY (Continue)

RETURN NEW GOODS

All claims for returns or adjustments must have prior approval and return authorization (RGA) number. Only original, sealed products in salable condition are eligible for return. Credit for authorized returns will be issued at the net price paid for the product and subject to a 15% restocking/handling fee. Merchandise is to be returned via prepaid freight. All unauthorized returns will be refused or subject to a 25% restocking/handling fee.

How to request an "RGA" number: Email customer service to obtain the "RGA" form (customerservice@Innoci-usa.com). Complete and return the form by email to customerservice@Innoci-usa.com with your name, address, phone number, fax number, email address, each quantity of units returning, customer P.O. #, product item number, description of product and the reason for return. We will send you a Return Authorization Number (RA) by return by email. Please take necessary precautions when returning merchandise to prevent additional damage. Insurance is the responsibility of the shipper.

SHORTAGE OR DAMAGED PRODUCTS

All shipments are carefully inspected and counted before leaving our distribution centers. Please inspect carefully on receipt of merchandise, noting any discrepancy or damage on the carrier's freight bill at that time

If you receive damage, please make a claim by email with pictures of the damaged product and damaged packaging customerservice@Innoci-usa.com

innoci usa, Inc.

14530 Best Ave.,
Santa Fe Springs, CA 90670

www.innoci-usa.com